

# LACERTOSUS<sup>®</sup>

## PRO POWER RACK / INSTRUCTIONS

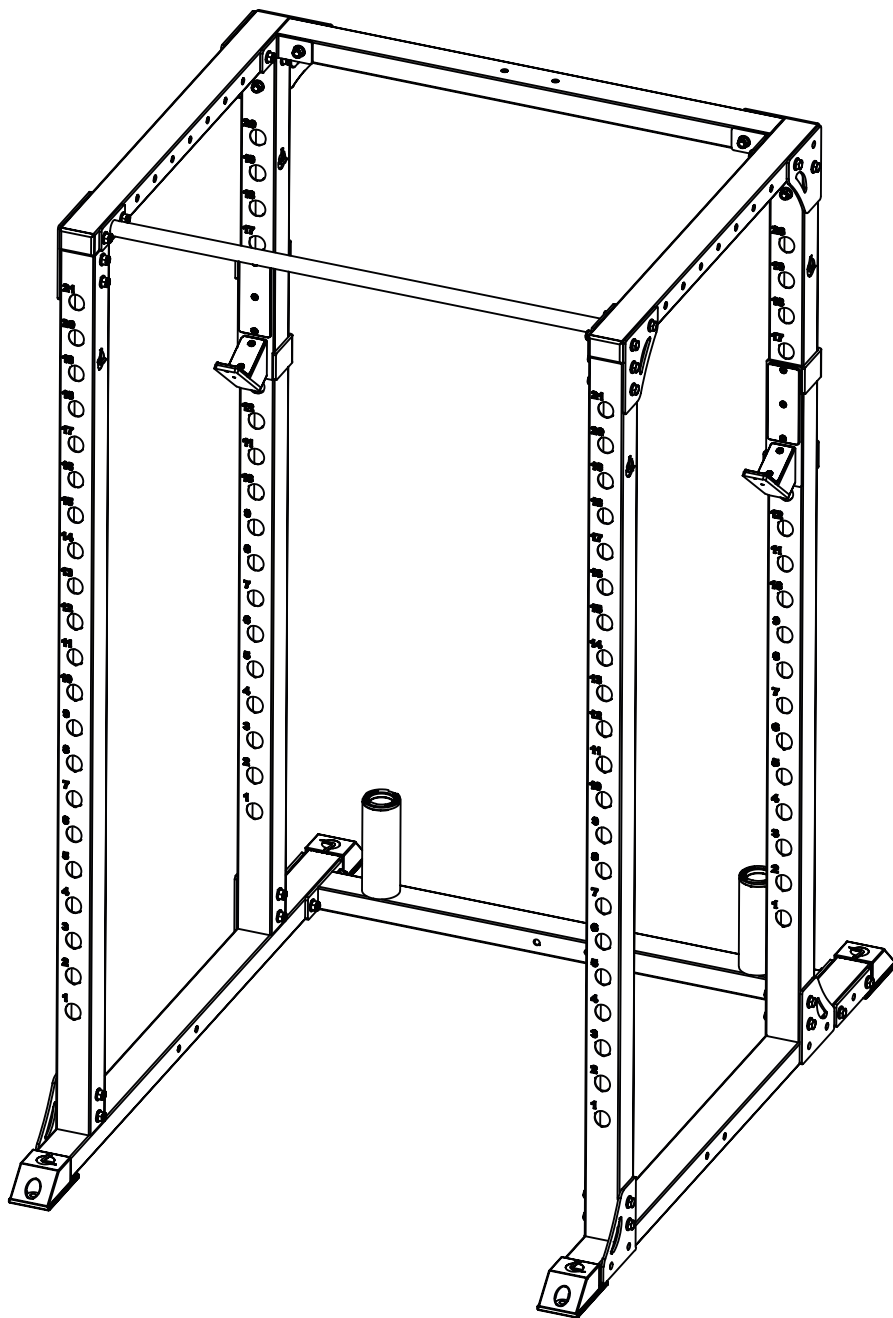

Thank you for choosing another high quality product from Lacertosus®, enjoy the installation and please get back to us in case you are facing problems!

And if this manual isn't enough:



Scan this qr code for the online instructions in english or italian

## BOLTS AND NUTS

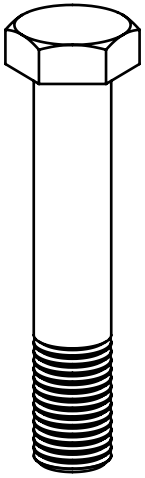

x4

Hex bolt  
M12x105

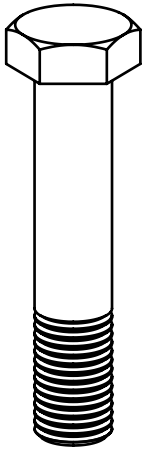

x8

Hex bolt  
M12x100

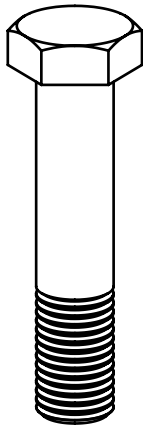

x16

Hex bolt  
M12x95

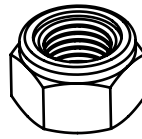

x28

Nut  
M12



x56

Flat washer  
Ø13.5xØ24

## REQUIRED TOOLS

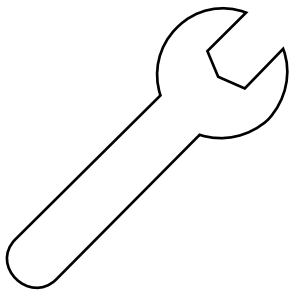

Wrench  
N19

\*For a simpler and faster assembly we recommend the use of two wrenches

## NOTES

[cm]

0 —  
—  
1 —  
—  
2 —  
—  
3 —  
—  
4 —  
—  
5 —  
—  
6 —  
—  
7 —  
—  
8 —  
—  
9 —  
—  
10 —  
—  
11 —  
—  
12 —  
—  
13 —  
—  
14 —  
—  
15 —  
—  
16 —  
—  
17 —  
—  
18 —  
—  
19 —  
—  
20 —  
—  
21 —  
—  
22 —  
—  
23 —

## PARTS LIST

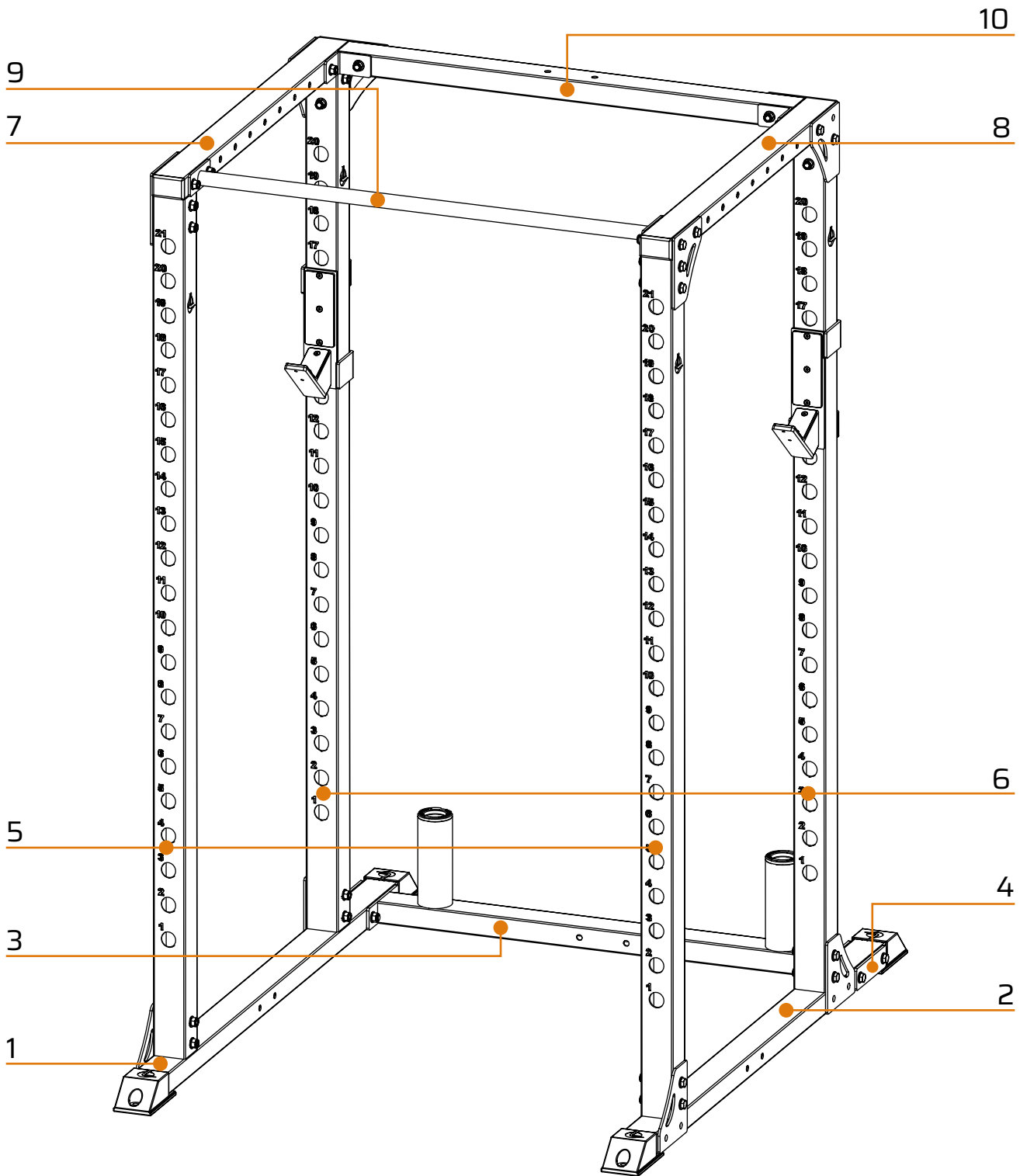

n	name	qty
1	left base tubular	1
2	right base tubular	1
3	rear base tubular	1
4	fixing plate	2
5	front upright pole	2

n	name	qty
6	rear upright pole	2
7	left top tubular	1
8	right top tubular	1
9	pull up bar	1
10	rear top tubular	1

\* before starting the assembly, remove all the components from the boxes and make sure that everything is there according to the list and previous indications.

## ASSEMBLY INSTRUCTIONS

1. Assemble the U-base on the ground using the left [1], right [2] and rear [3] base tubular and the fixing plates [4], tightening the bolts

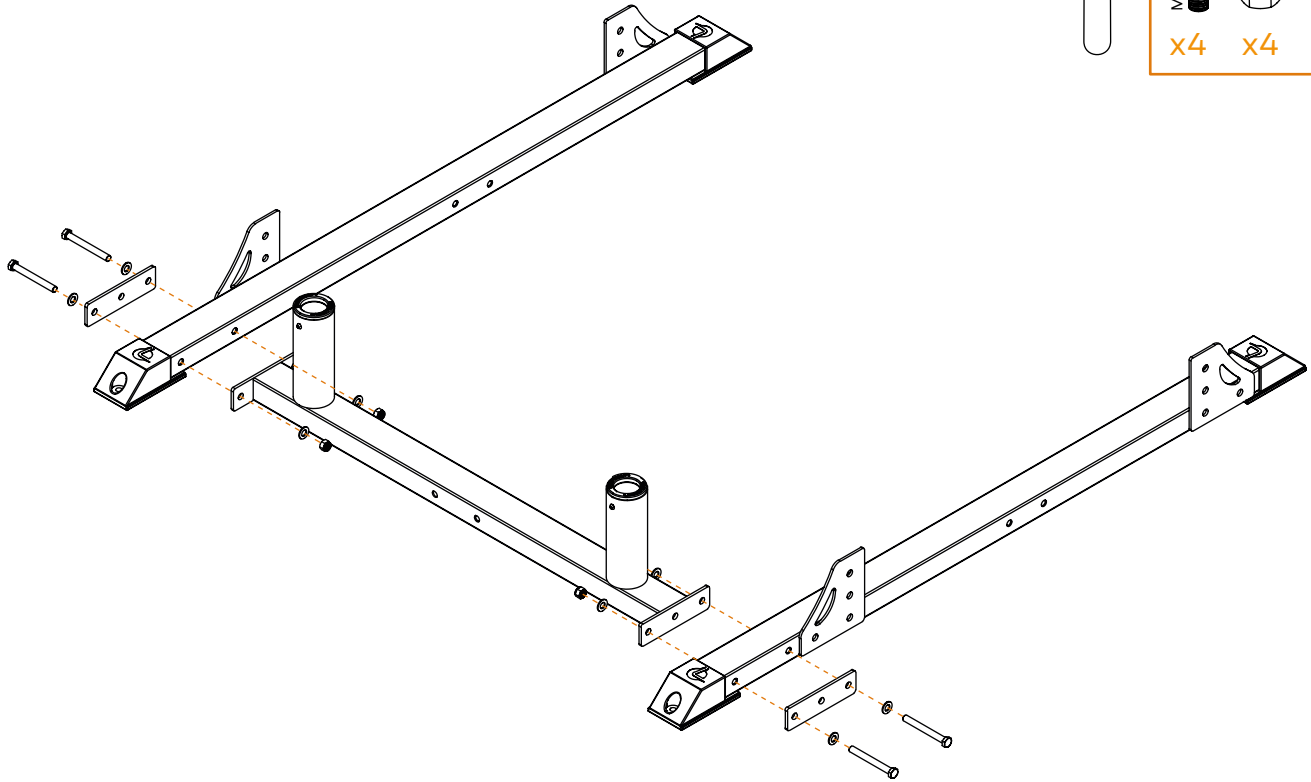

2. Assemble the front [5] and rear [6] upright poles to the U-base tightening the bolts.

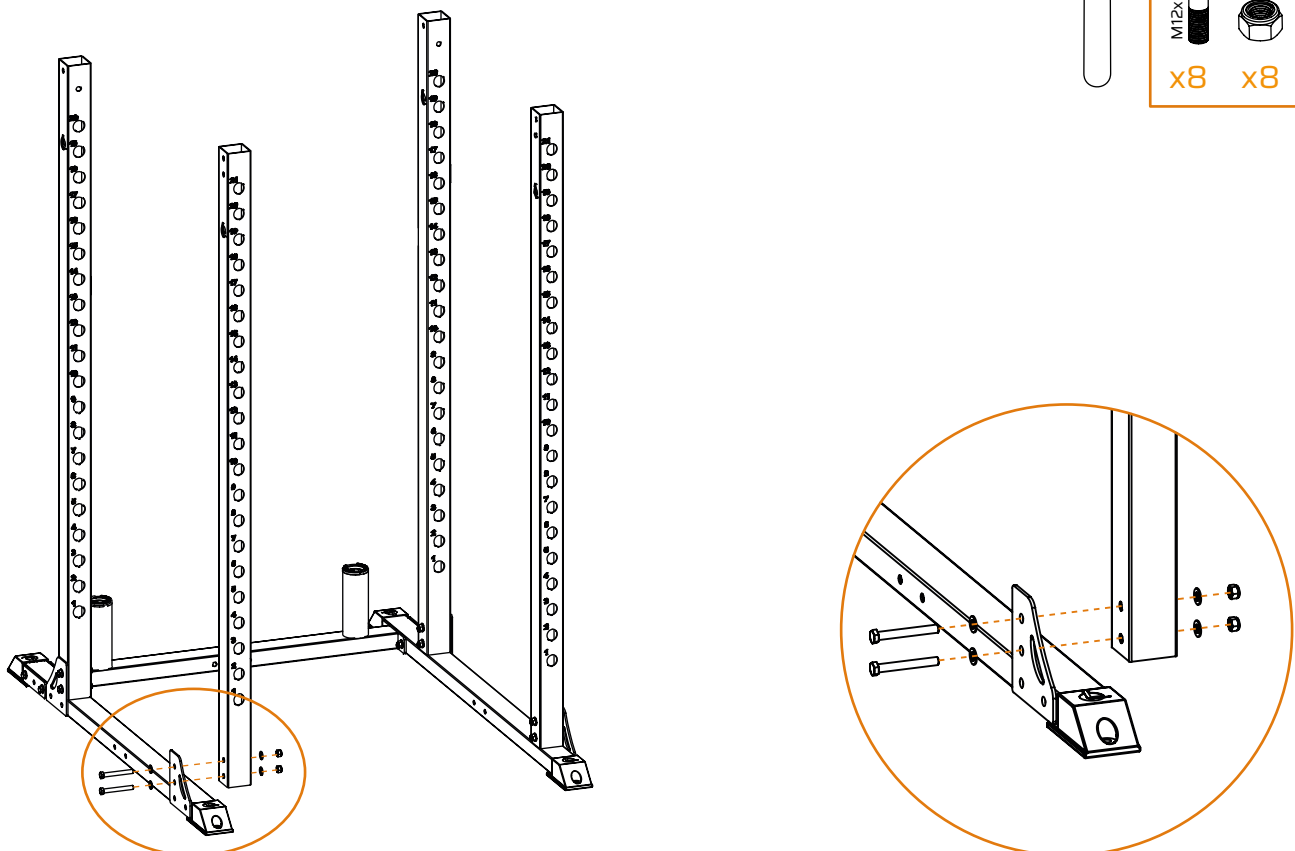

3. Assemble the left [7] and right [8] top tubular to the upright poles tightening the bolts.

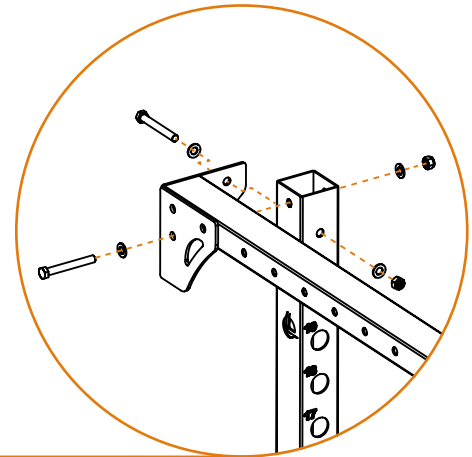
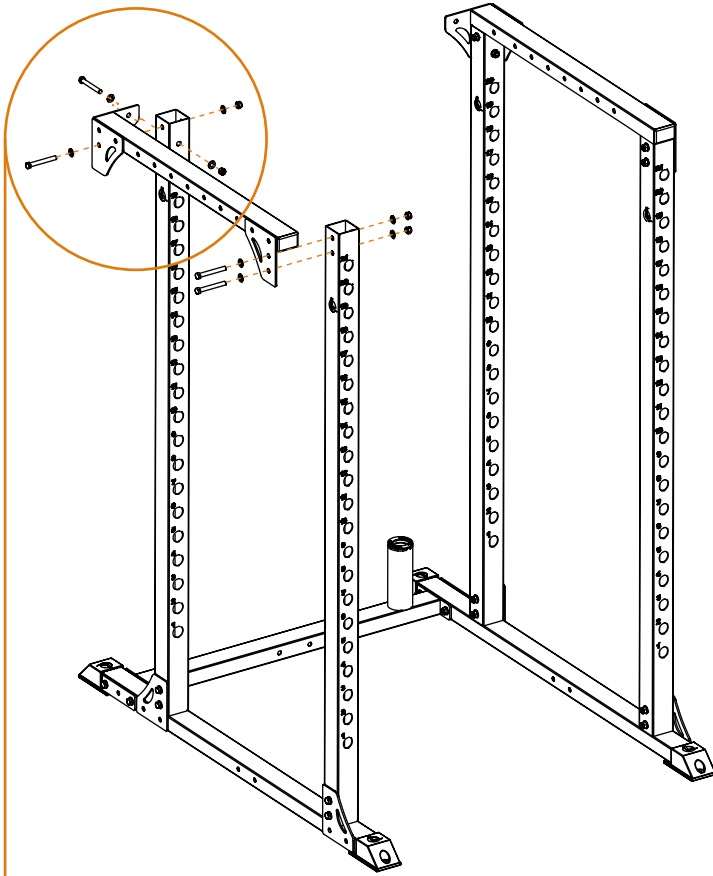
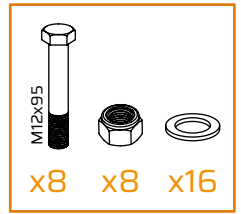
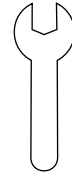

4. Assemble the pull up bar [9] and the rear top tubular [10] tightening the bolts.

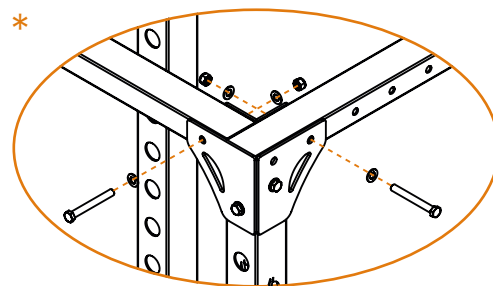
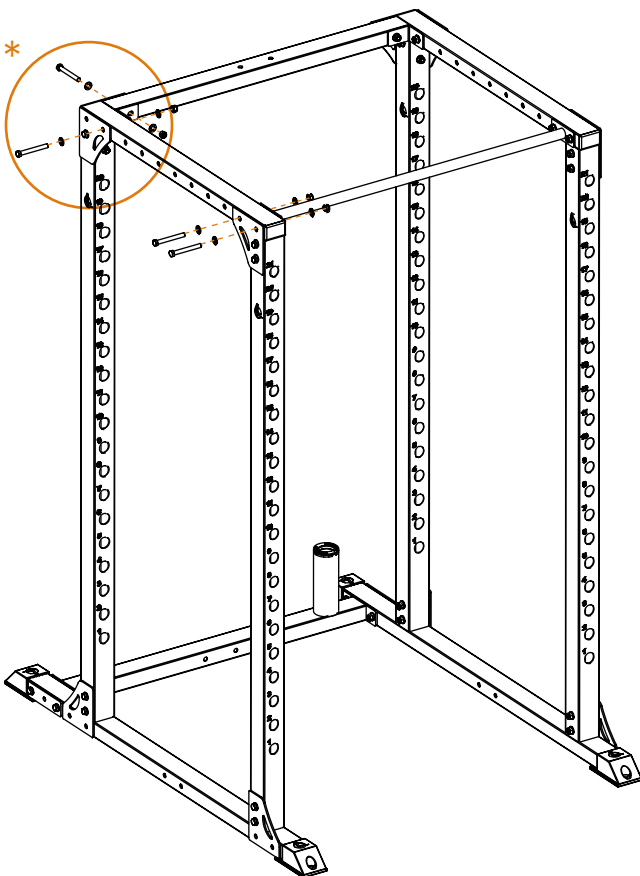
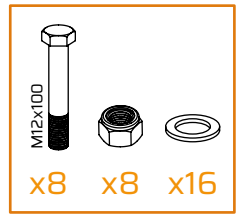
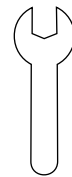

detail of the back view

5. Add the Hooks and enjoy your new training partner!

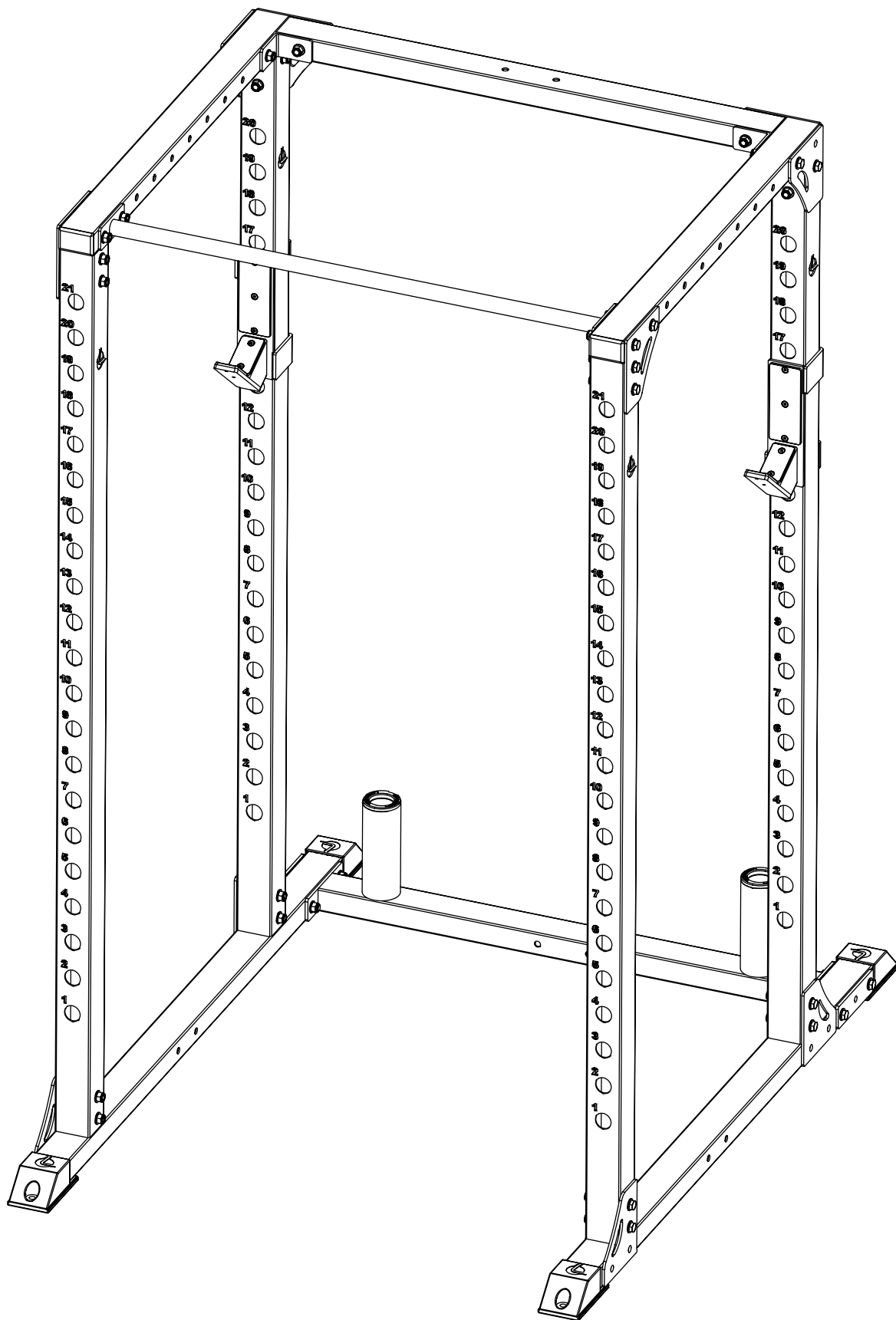

THANK YOU FOR CHOOSING  
**LACERTOSUS**<sup>®</sup>

copyright © 2020 Lacertosus SRL | Lacertosus<sup>®</sup> is a registered trademark | [info@lacertosus.com](mailto:info@lacertosus.com)

---

release date 12/2020  
rev.0 12/2020

# LACERTOSUS<sup>®</sup>

PRO POWER RACK / ISTRUZIONI

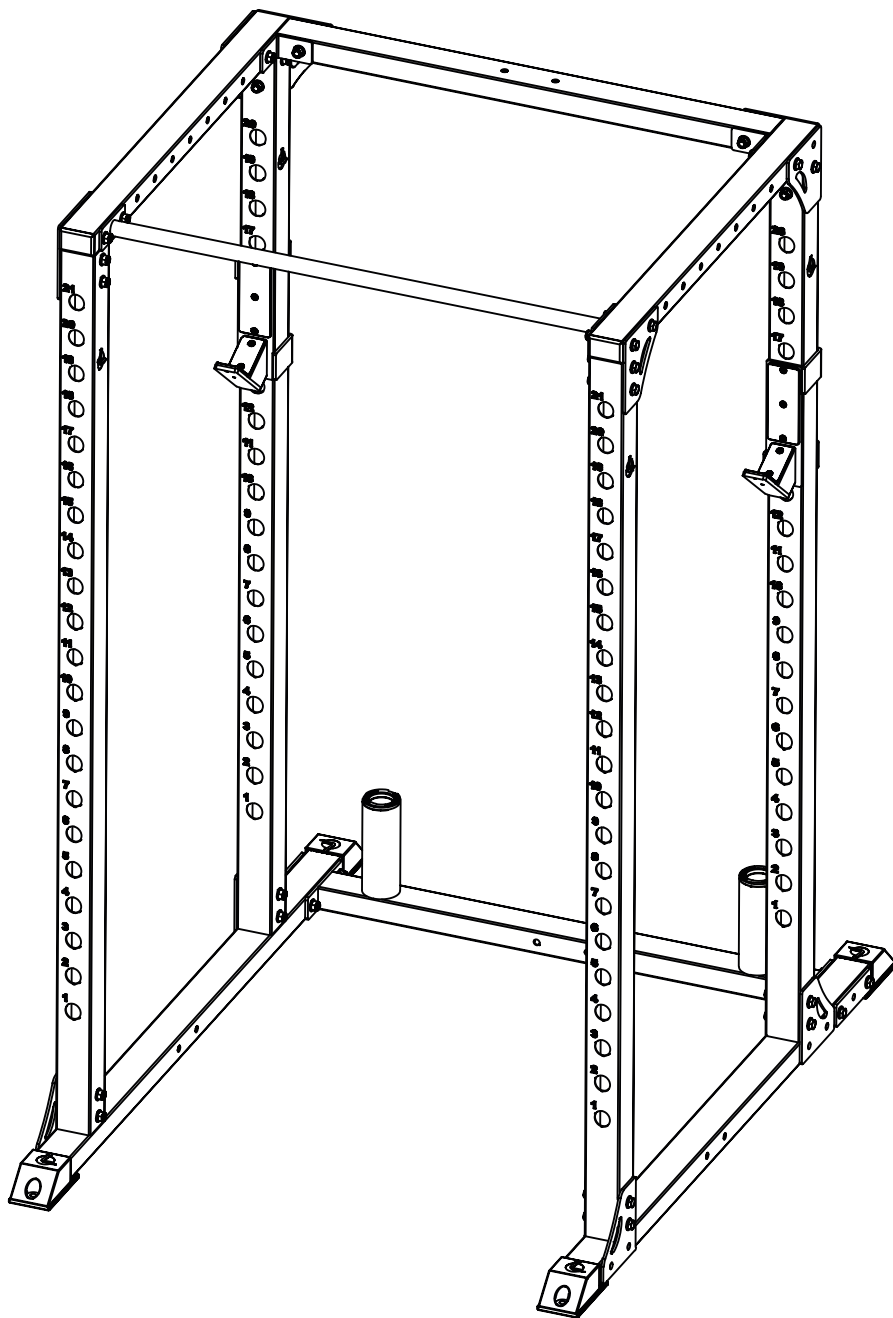



Grazie per aver scelto un altro prodotto di qualità firmata Lacertosus®, goditi l'installazione e qualora dovessi riscontrare problemi ti preghiamo di contattarci!

E se pensi che questo manuale non sia abbastanza



Scannerizza il codice QR per accedere alle istruzioni online

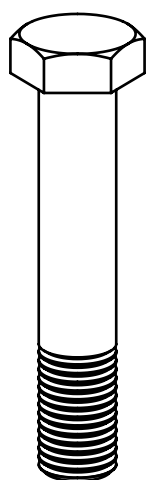

x4

Vite a testa esagonale  
M12x105

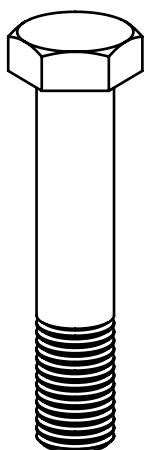

x8

Vite a testa esagonale  
M12x100

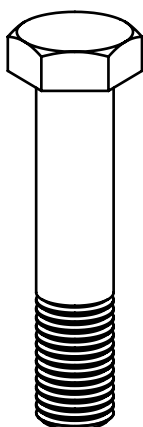

x16

Vite a testa esagonale  
M12x95

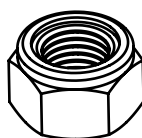

x28

Dado  
M12



x56

Rondella  
Ø13.5xØ24

[cm]

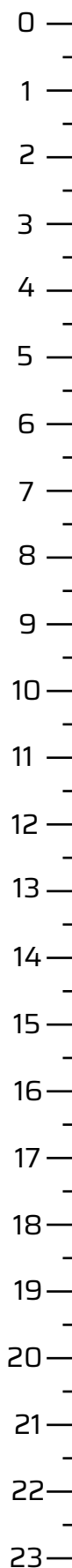

## ATTREZZI RICHIESTI

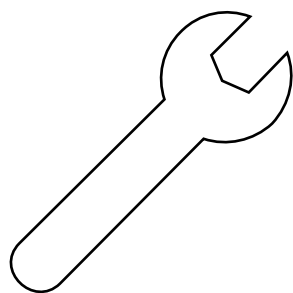

chiave  
N19

\*Per un montaggio più semplice e veloce si consiglia l'uso di due chiavi

## NOTE

## LISTA DEI COMPONENTI

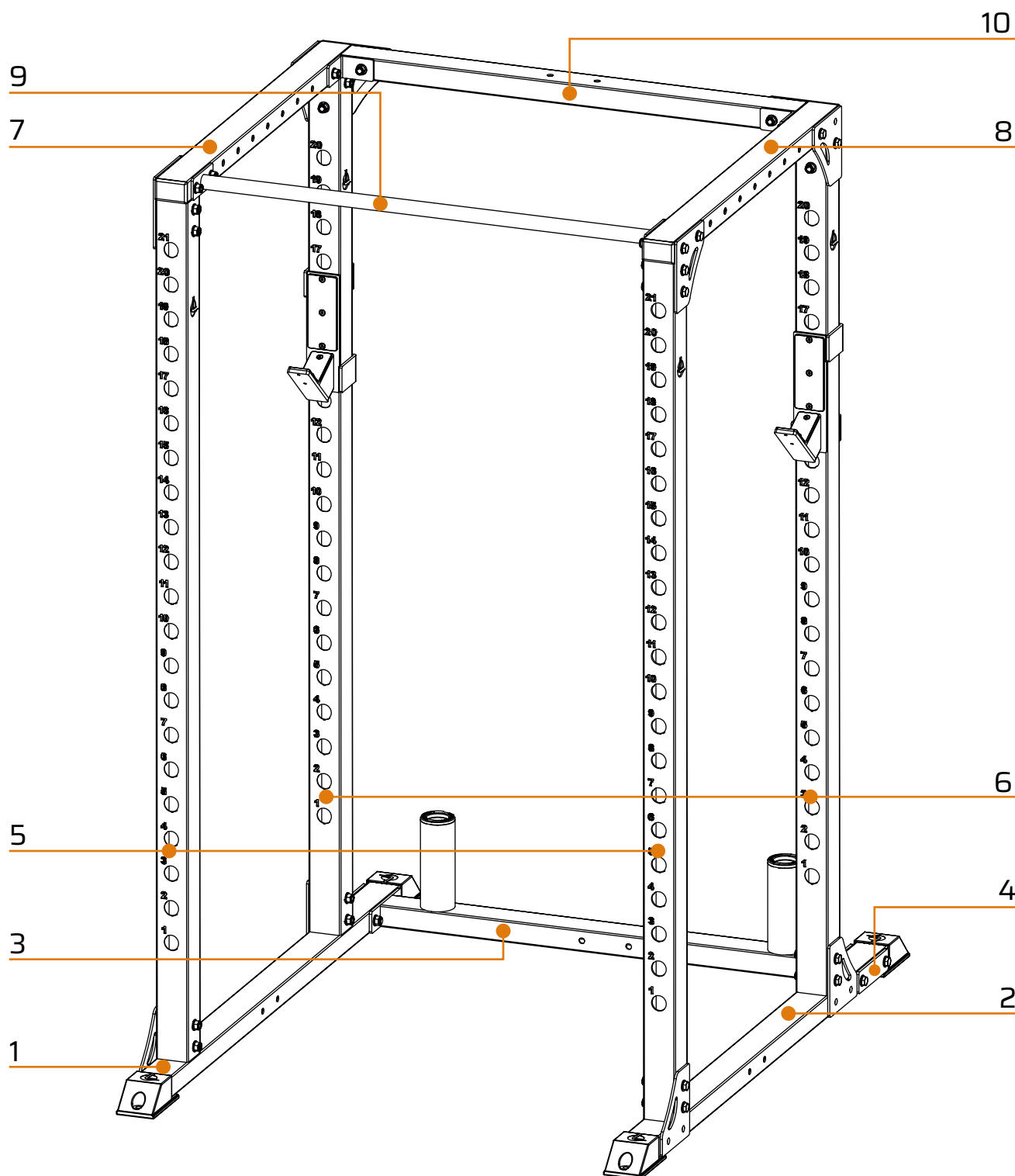

n	nome	qntà
1	profilo sx base	1
2	profilo dx base	1
3	profilo post base	1
4	piastra di fissaggio	2
5	palo verticale ant	2

n	nome	qntà
6	palo verticale post	2
7	profilo sx superiore	1
8	profilo dx superiore	1
9	sbarra per trazioni	1
10	profilo post superiore	1

\* prima di iniziare il montaggio, rimuovere tutti i pezzi dalle scatole e assicurarsi che siano presenti tutti i componenti precedentemente indicati

## ISTRUZIONI DI ASSEMBLAGGIO

1. Assemblare a terra la base a U utilizzando il profilo sinistro [1], destro [2] e posteriore [3] impiegando le due piastre di fissaggio [4], stringere bene le viti.

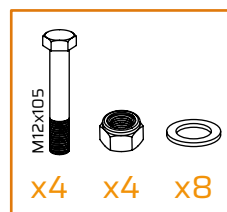
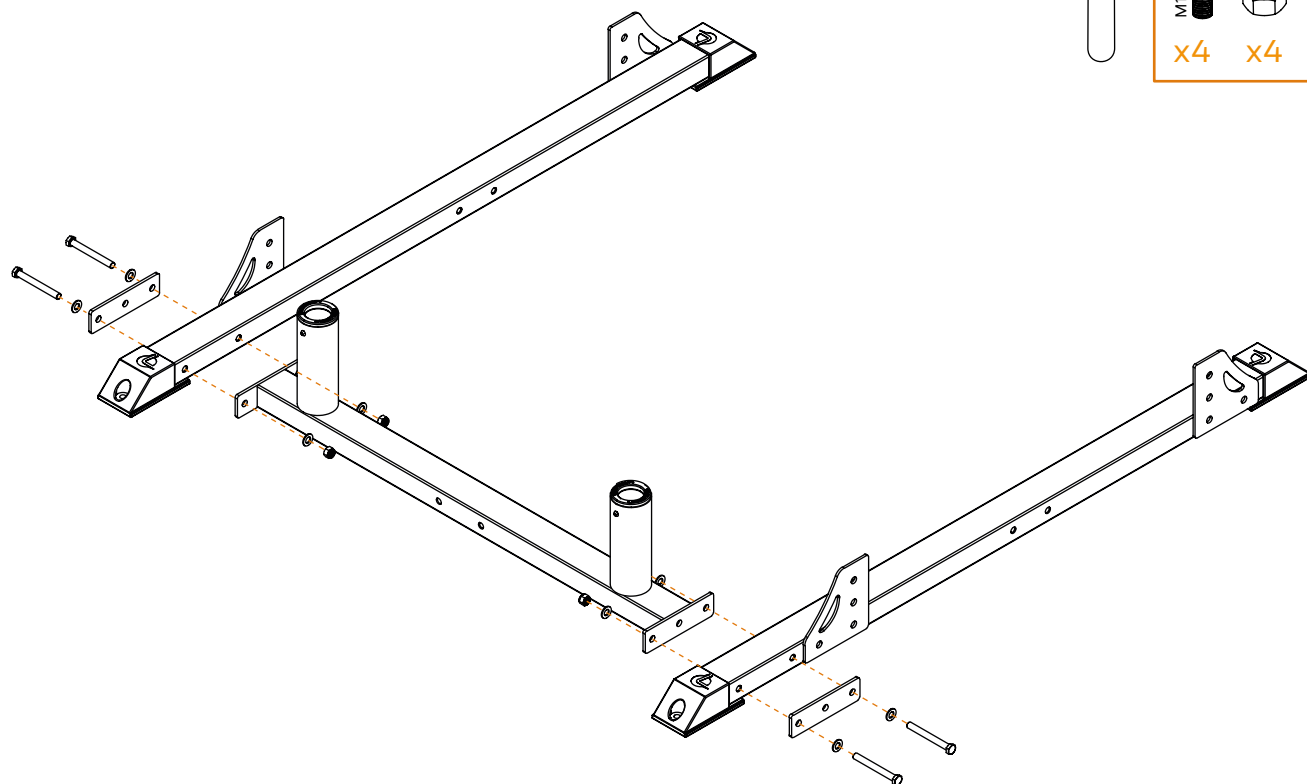

2. Assemblare alla base ad U i pali anteriori [5] e posteriori [6] sfruttando le apposite piastre e stringere le viti.

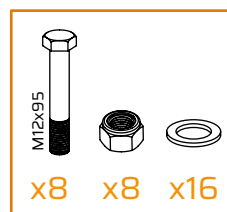
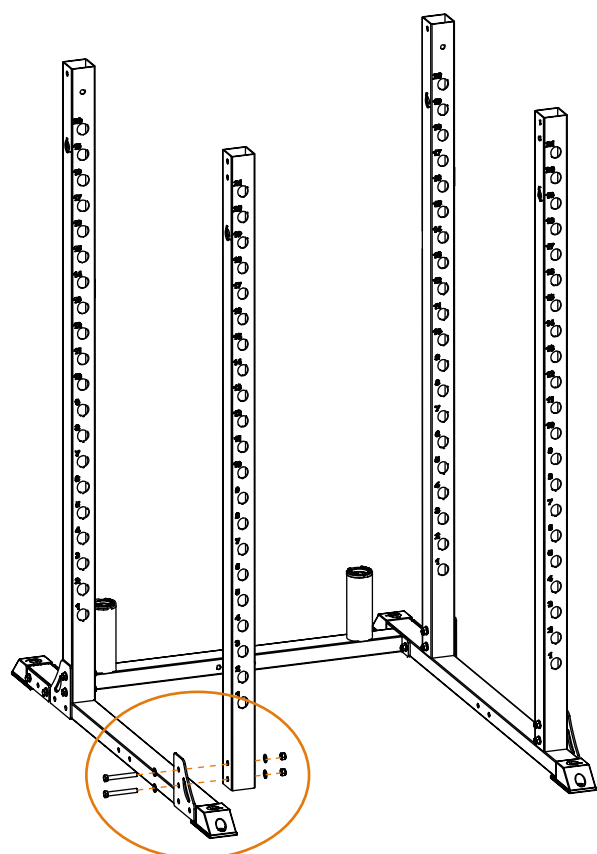

3. Assemblare il profilo superiore sinistro [7] e destro [8] ai pali verticali sfruttando le apposite piastre e stringendo bene le viti.

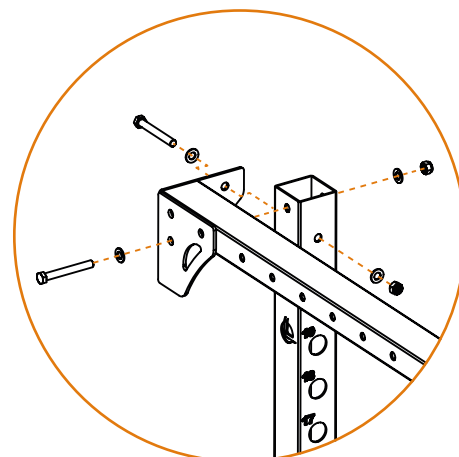
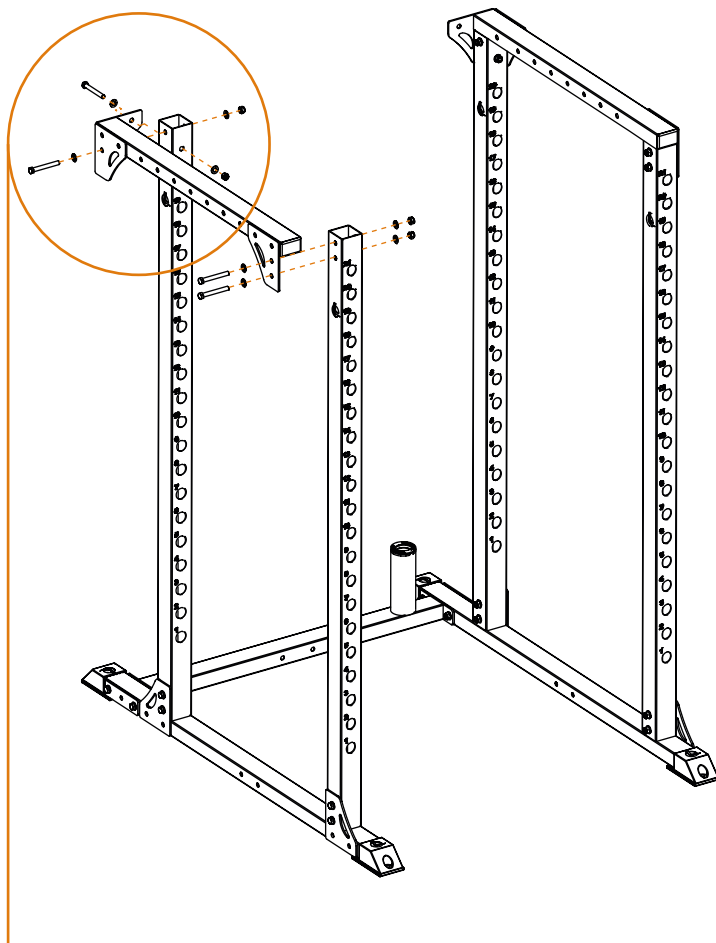
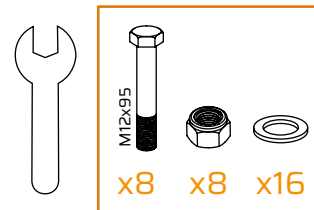

4. Assemblare ai profili appena installati la sbarra per trazioni [9] e il profilo posteriore [10] assicurando bene le viti.

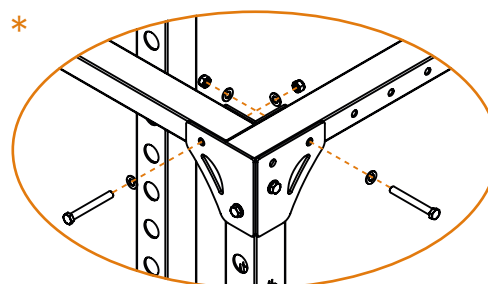
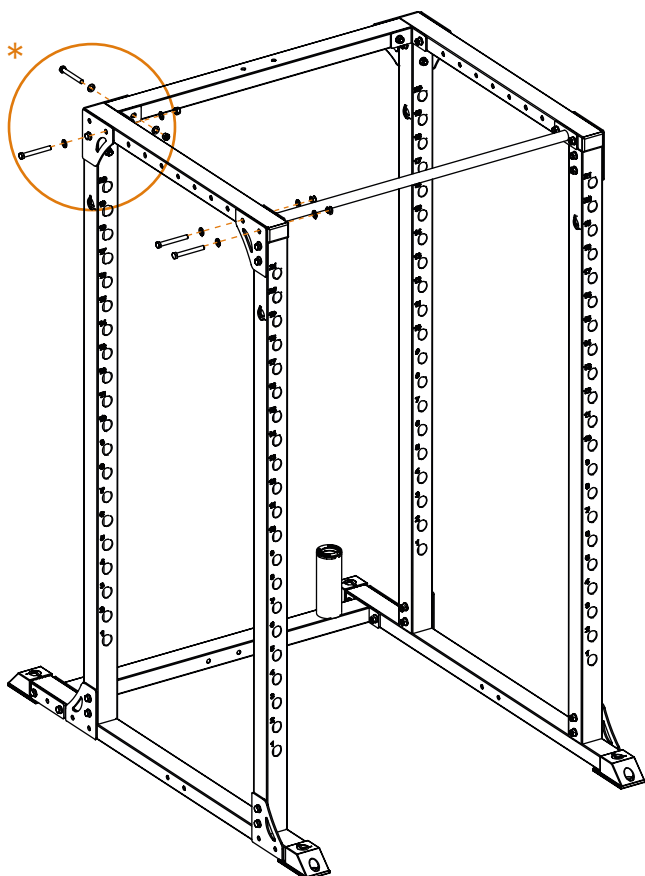
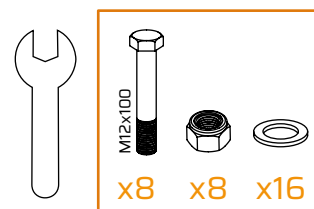

dettaglio della vista posteriore

5. Aggiungi gli accessori e goditi la tua nuova attrezzatura!

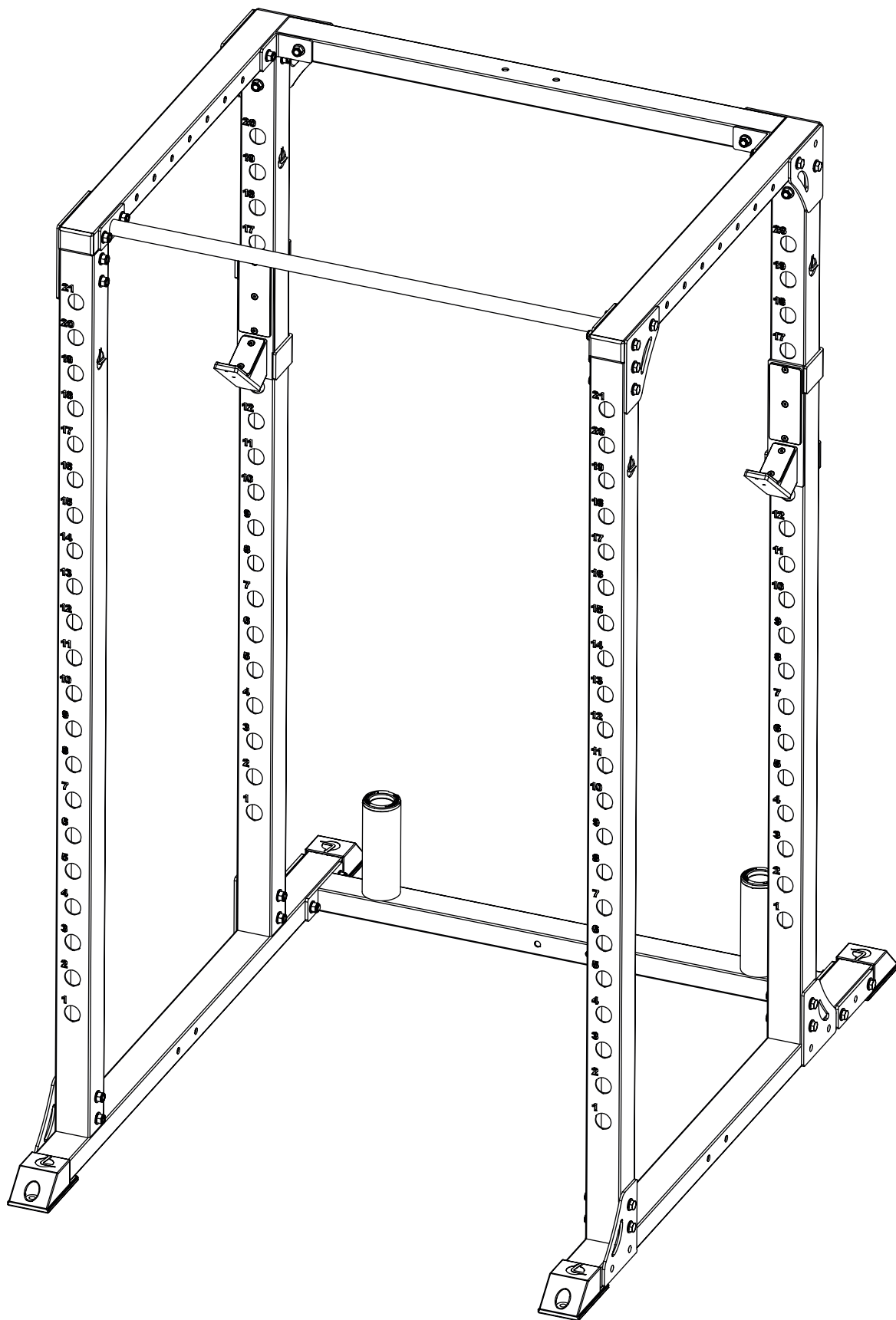

THANK YOU FOR CHOOSING  
**LACERTOSUS**<sup>®</sup>

copyright © 2020 Lacertosus SRL | Lacertosus<sup>®</sup> is a registered trademark | [info@lacertosus.com](mailto:info@lacertosus.com)

---

release date 12/2020  
rev.0 12/2020